

**6-7 Magnetism and electromagnetism – Trilogy**

**1.1** This question is about magnets.

Which statements apply to **permanent magnets**, which apply to **electromagnets** and which apply to **both**?

Tick the correct boxes.

[2 marks]

	<b>Permanent magnets</b>	<b>Electromagnets</b>	<b>Both</b>
Need an electric current to work			
Have a constant magnetic field			
Can be turned off			
Have north and south poles			
Often contain a coil of wire			

**1.2** What is an **induced** magnet?

Tick the correct box.

[1 mark]

- A permanent magnet made by passing a current through a piece of steel
- A temporary magnet made by repeatedly heating a piece of steel
- A permanent magnet made by repeatedly stroking a piece of steel with a magnet
- A temporary magnet made by touching a piece of steel with another magnet

1.3 Describe how to find the direction of the magnetic field around a permanent magnet using a small compass.

[3 marks]

---



---



---



---



---



---

2.0 A student was investigating the effect of the size of current on the strength of an electromagnet.

Figure 1 shows the equipment she used.

Figure 1

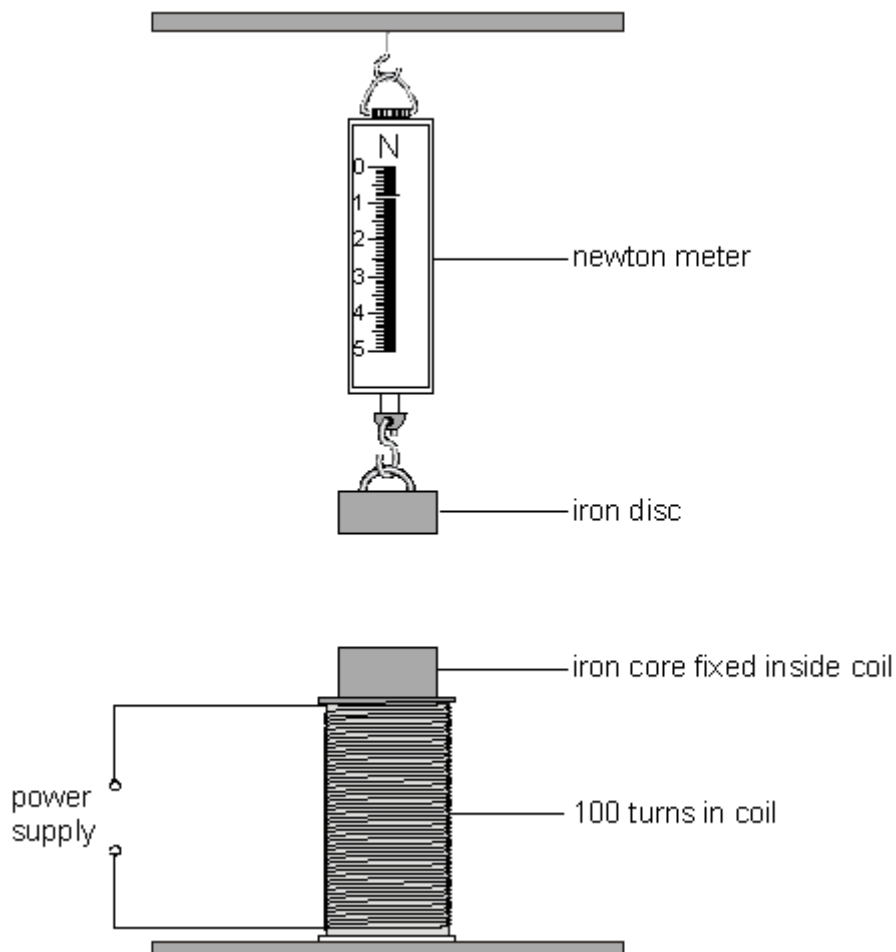

**2.1** Describe how the student could carry out an investigation to find the relationship between the current in the coil and the force on the iron disc.

**[4 marks]**

---

---

---

---

---

---

---

---

---

---

2.2 The student made two electromagnets, one with 100 turns of wire in the coil and one with 200 turns. She carried out the investigation with each of the coils and plotted **Graph 1**.

**Graph 1**

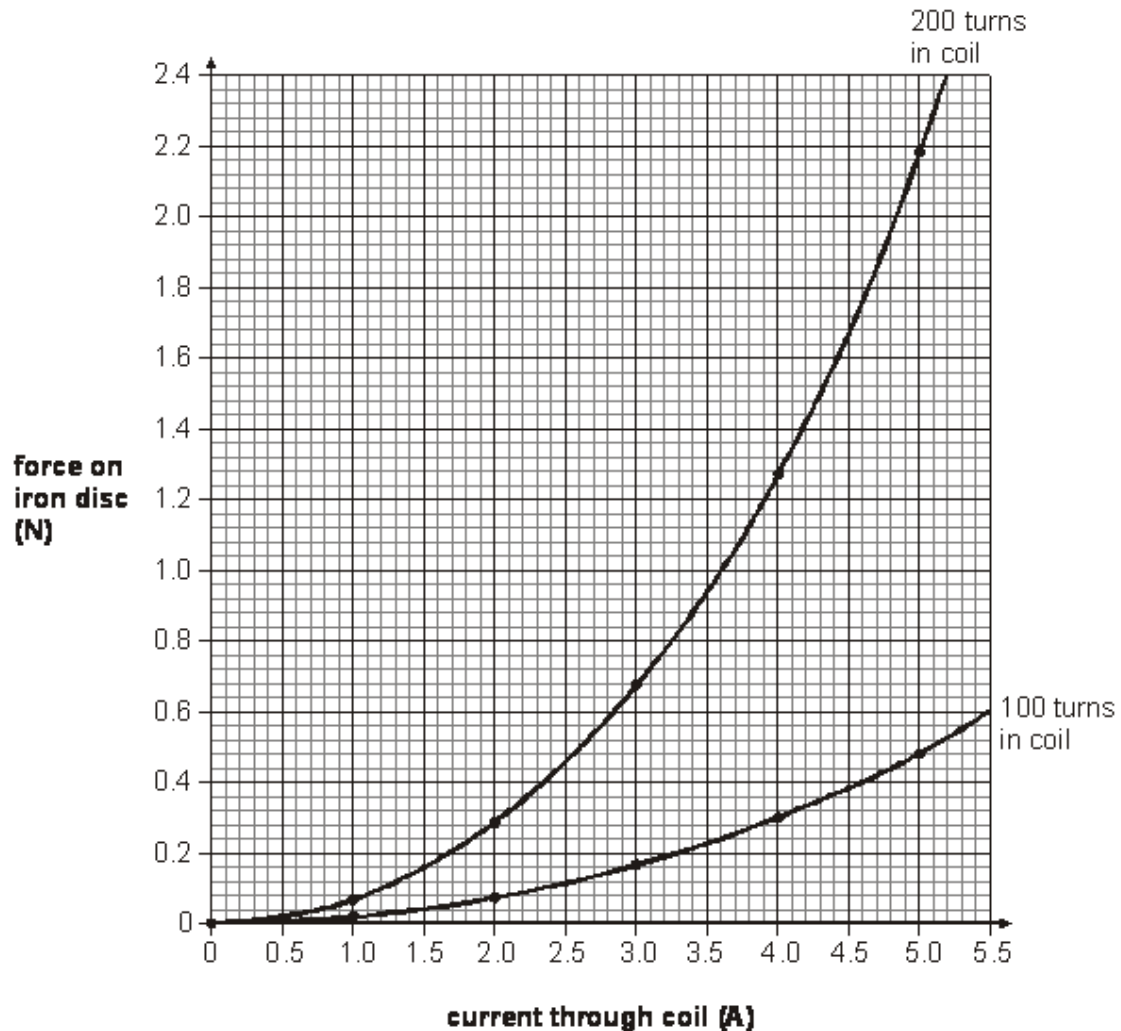

The student wanted to find the ratio of the force from the two different coils at each current.

Her results are shown in **Table 1**.

**Table 1**

Current	100 coils	200 coils	ratio
1.0	0.02	0.07	1 : 3.50
2.0	0.08	0.28	1 : 3.50
3.0	0.16	0.68	1 : 4.25
4.0	0.30	1.28	1 : 4.27
5.0			

Complete the last row on **Table 1**.

[2 marks]

2.3 The student wrote the following conclusion:

*The relationship between the current and the ratio of the force from the two coils is directly proportional.*

Was the student correct?

Explain your answer.

[2 marks]

---



---



---



---



---

3.0 The left-hand rule can be used to identify the direction of the force acting on a current-carrying conductor in a magnetic field.

3.1 Use words and phrases from the box to label **Figure 2**.

[3 marks]

current	force	magnetic field	magnetic flux density	potential difference
---------	-------	----------------	-----------------------	----------------------

**Figure 2**

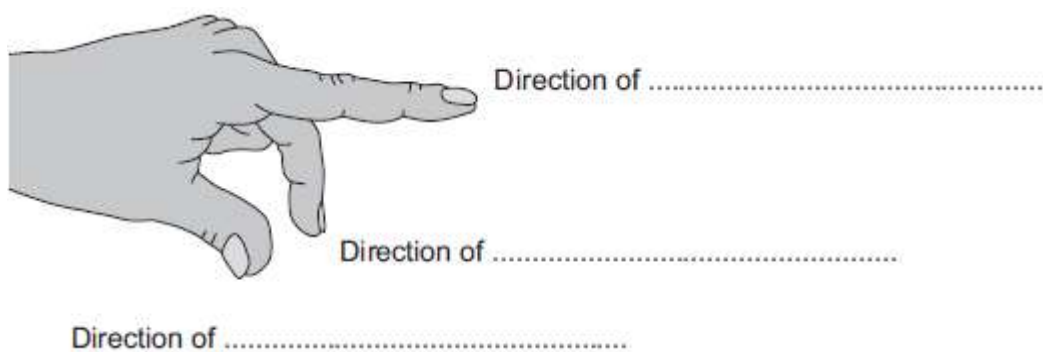
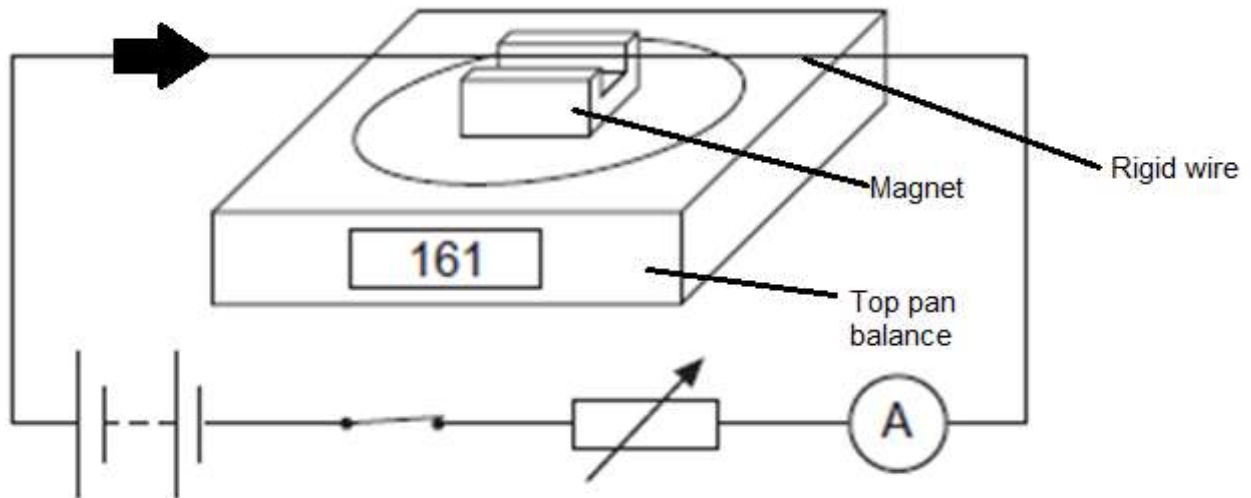

Figure 3 shows a wire held between the poles of a U-shaped magnet on a top pan balance.

Figure 3



The magnet was placed on the top pan balance before the current was switched on.  
 The balance was then zeroed.  
 After the current was switched on, the balance read 161 g.  
 The arrow shows the direction of the current in the circuit.

3.2 Which direction was the force on the **balance**?

Tick the correct box.

[1 mark]

- In the same direction as the arrow
- Down onto the balance
- Up from the balance
- From the front of the balance to the back of the balance

3.3 Due to Newton's third law of motion, the force on the **wire** is in the **opposite** direction to the force on the balance.

Which direction was the magnetic field?

Tick the correct box.

[1 mark]

In the same direction as the arrow

Down onto the balance

Up from the balance

From the front of the balance to the back of the balance

3.4 Explain what would happen to the reading on the balance if the current in the wire was increased.

[2 marks]

---

---

---

---

4.0 One simple design of an electric motor is shown in the **Figure 4**. It has a coil which spins between the poles of two magnets.

**Figure 4**

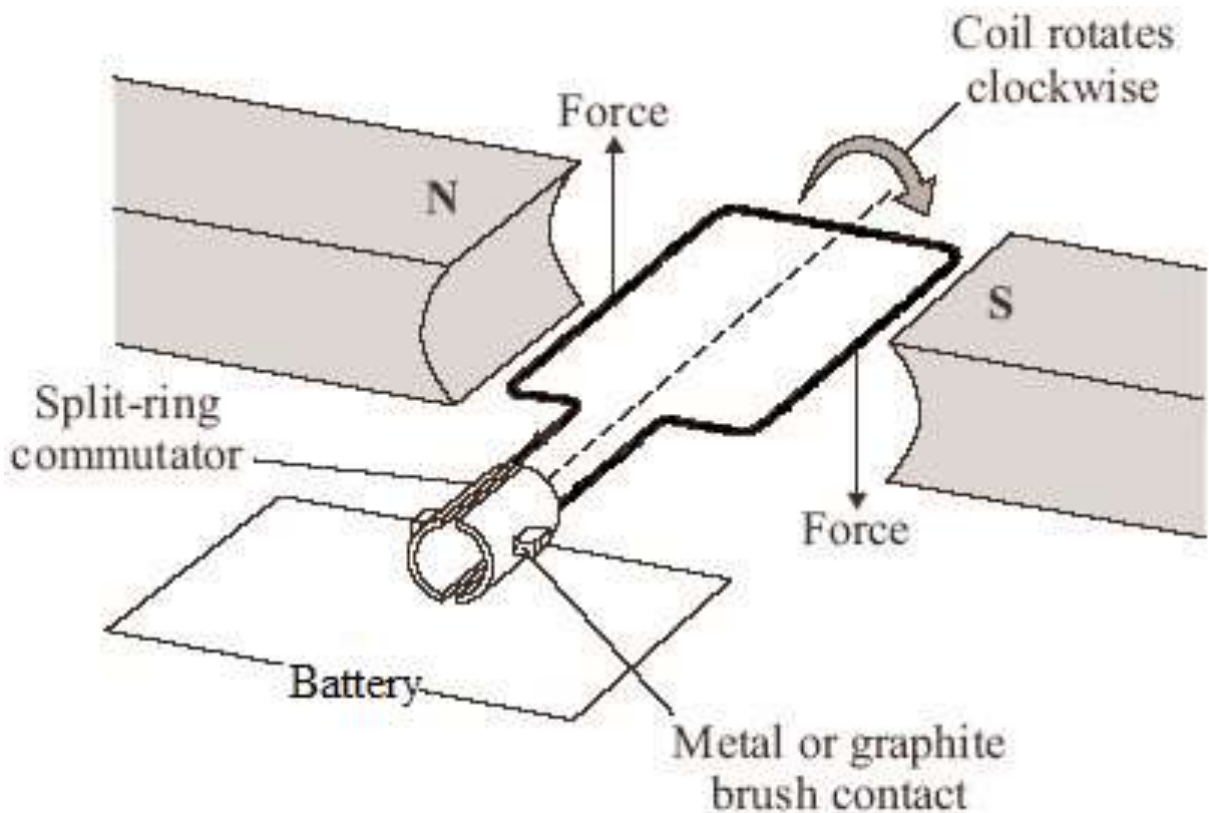

4.1 Add an arrow to **figure 4** showing the direction of the current in the wire from the battery.

[1 mark]

4.2 The motor is part of an electric drill. It needs to be able to change direction and speed. Describe how the **direction** and **speed** of the drill could be varied **without** changing the way the motor is constructed.

[2 marks]

Direction: \_\_\_\_\_

\_\_\_\_\_

Speed: \_\_\_\_\_

\_\_\_\_\_



- 4.3 A student builds a model motor. The magnetic field between the poles is  $3 \times 10^{-2}$  T. The length of one side of the coil in between the poles is 2 cm. The current is 0.5 A. Calculate the force on the coil. Give your answer in standard form.

[2 marks]

Force: \_\_\_\_\_ N

- 5.0 Figure 5 shows a part of the National Grid.

Figure 5

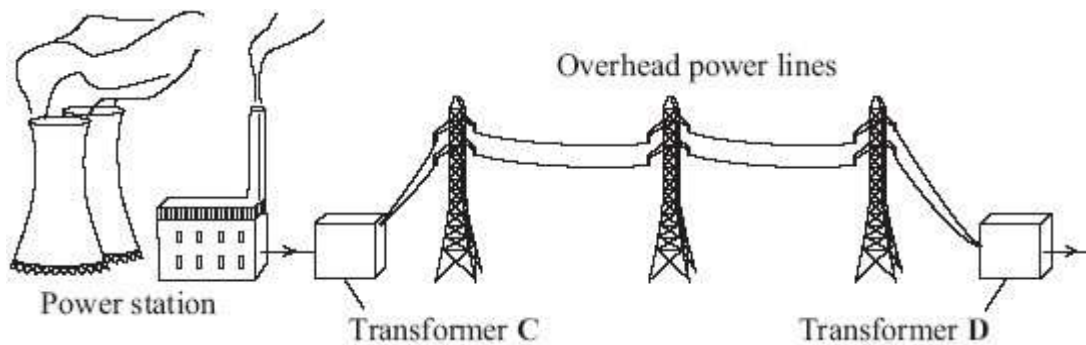

- 5.1 Explain why **two** different types of transformers are needed in the National Grid.

[3 marks]

---



---



---



---



---



---



---

The cables used in the National Grid can either be suspended from pylons and run overhead, or buried underground.

When an electric current flows through a transmission cable, a magnetic field is produced.

Figure 6 shows how the strength of the magnetic field varies with distance from both overhead and underground transmission cables that carry the same current.

Figure 6

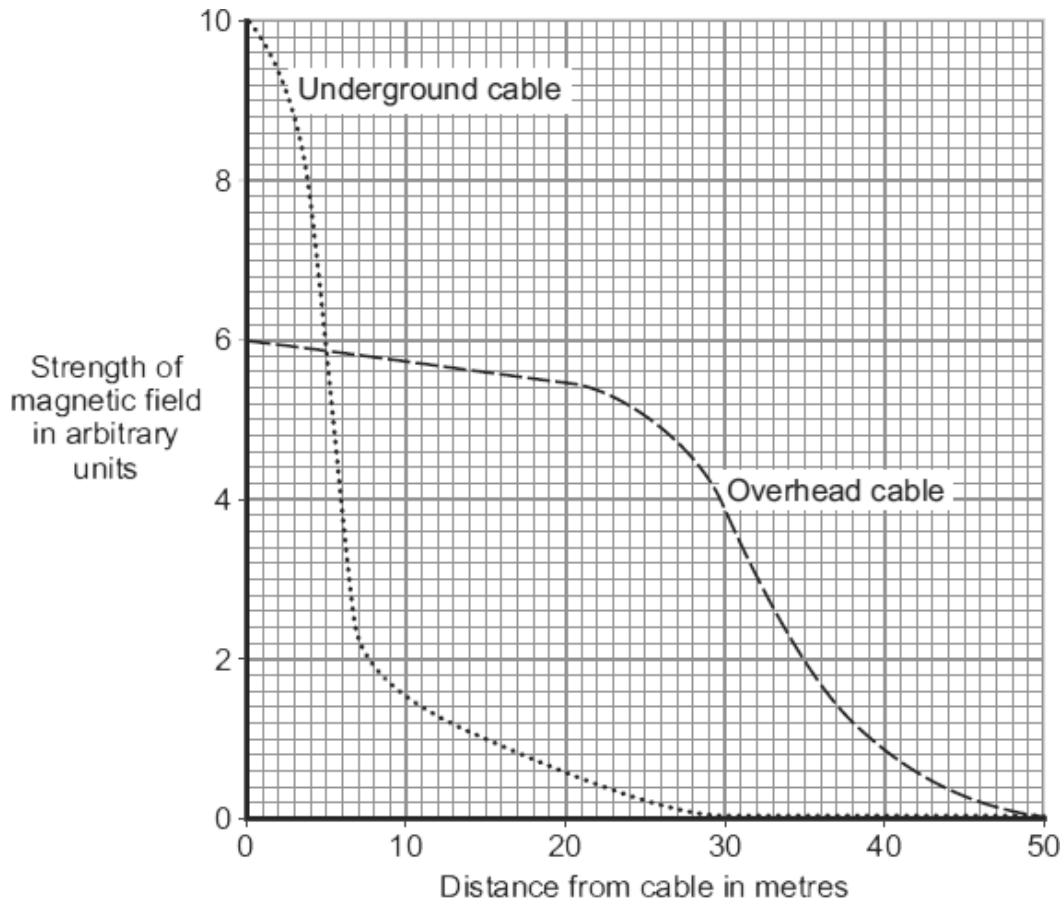

5.2 A politician sees **Figure 6** and says “Underground cables are safer as they have a lower strength of magnetic field.”

Evaluate his claim.

[2 marks]

---



---



---



---

5.3 The slope of the graph shows the rate of change of magnetic field strength with distance.

Calculate the slope of the graph for the overhead cable between 0 and 20 m.

[2 marks]

Rate of change of magnetic field with distance: \_\_\_\_\_ /m

## MARK SCHEME

Qu No.			Extra Information	Marks
1.1	Need an electric current to work	Electromagnets	All rows correct: 2 marks 3 or 4 rows correct: 1 mark	2
	Have a constant magnetic field	Permanent magnets		
	Can be turned off	Electromagnets		
	Have north and south poles	Both		
	Often contain a coil of wire	Electromagnets		
1.2	A temporary magnet made by touching a piece of steel with another magnet			1
1.3	Place compass at different points around the compass		Accept clearly labelled diagram for any or all points	1
	Indication of how to draw eg note down the direction of the compass at each point around the magnet / compass points along field lines			1
	Join each individual direction to form field lines			1

Qu No.			Extra Information	Marks
2.1				
<b>Level 2:</b>	A clear, coherent description of a safe experiment with given values of current (eg 0.5, 1.0, etc up to a maximum of about 5A) and details of repeats. Includes letting the equipment cool down between experiments.			3-4
<b>Level 1:</b>	A description of an experiment that would allow valid results to be obtained. May include currents higher than 5 A or omit details of number of readings to be taken or repeat measurements.			1-2
<b>Indicative content</b>				
	Set current to small value Measure force on the iron disc Repeat at regular increases of current Repeat at least 2 more times Allow equipment to cool between measurements			
2.2	0.48 and 2.18		Allow +/- 0.2 for each reading	1
	4.54		Allow ecf from marking point 1	1
2.3	(No)			1
	The ratio increases with increased current But as not in a linear fashion / example given			1

Qu No.		Extra Information	Marks
3.1	Magnetic field Current Force	Correct order only	1 1 1
3.2	Down onto the balance		1
3.3	From the front of the balance to the back of the balance		1
3.4	Reading would increase As the magnetic flux density would increase		1 1

Qu No.		Extra Information	Marks
4.1	Arrow showing anticlockwise movement of the current		1
4.2	Direction: Change direction of current Speed: Change amount of current		1 1
4.3	$F = BIL = 3 \times 10^{-2} \times 0.5 \times 0.04$ $= 6 \times 10^{-4} \text{ (N)}$		1 1

Qu No.		Extra Information	Marks
5.1	To step up voltage (across the cables)/decrease the current (through the cables) Reduces thermal energy transfer / Increases efficiency (in the cables) Then step down voltage (across the cables) / increase the current (through the cables) (near users)		1 1 1
5.2	<b>One of:</b> Politician is correct that magnetic field from underground cable drops off in short distance <b>Or</b> But it starts higher  No link to safety in the graph / no health effects		1  1
5.3	Slope = $(5.4-6.0)/20$ $= -0.03 \text{ (/m)}$	Allow 0.03 for one mark	1 1